

® DU PONT
REGISTERED
TRADEMARK

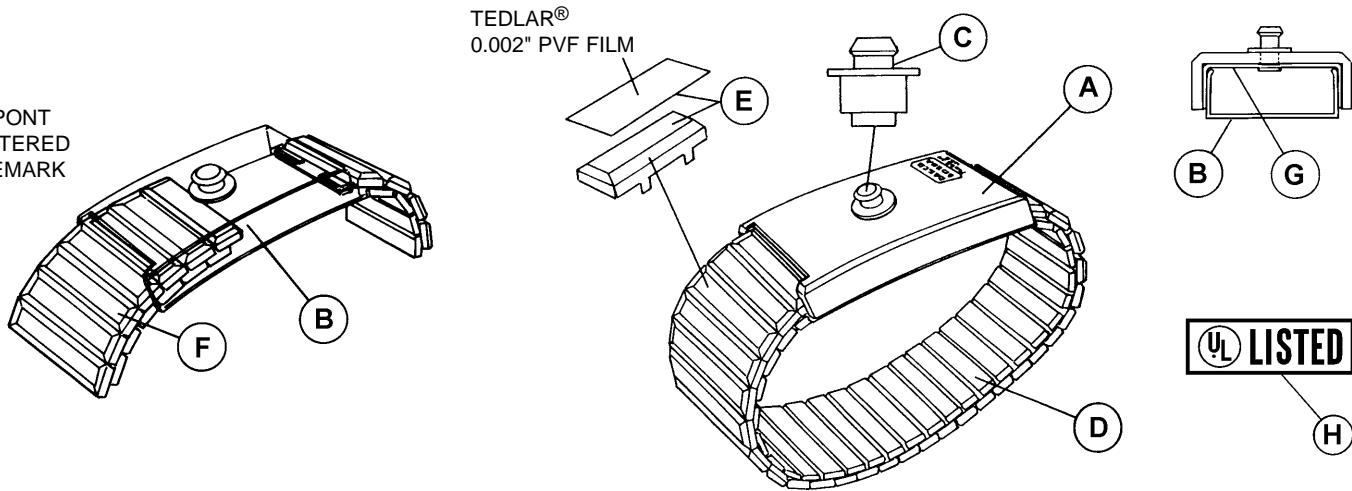

- A. Fixed black glass-filled nylon cap with slotted opening to allow size adjustment.
- B. 300 Series Stainless Steel Backplate forms channel to hold up to 10 links of band allowing size adjustment.
- C. 4mm snap stud machined from 300 series stainless steel. Fits to 4mm spring loaded medical type socket. Coil cord disengages from snap with 1-5 lbs. of perpendicular force. Durable, providing long life well beyond that of sheet metal snaps.
- D. Speidel® Twist-O-Flex® metal expansion band. Inside links are constructed of 300 Series Stainless Steel. Width of links is 0.630".

- E. .002" polyvinylfluoride sheet is laminated to each link. Provides 5,000 volt RMS insulation per ASTM D149-81. Scratch resistant.
- F. Size is adjusted by sliding 1 to 10 links of the band into the backplate "C" channel. Patented adjustment feature, US Patent #5,036,423.
- G. 300 Series Stainless Steel clip for electrical contact between snap stud and backplate.
- H. Underwriters Laboratory listing 90P1C.

Meets or exceeds requirements of EOS/ESD-S1-1987.

© Speidel and Twist-O-Flex are Registered Trademarks of Hirsch Speidel Inc.
U.S. Patents 5,036,423 and 5,568,351

ITEM	Description	Minimum Circumference	Maximum Circumference
09041	Band only	5.75 in.	13 in.
09042	Band only, X-large	6.25 in.	19.5 in.
09085	Band with 6 ft. coil cord	5.75 in.	13 in.
91070	Band, 6ft. cord & angle banana	5.75 in.	13 in.

Made in U.S.A.

WRISTBAND, METAL EXPANSION, ADJUSTABLE SIZE, STATIC CONTROL

DESCO WEST: 3651 WALNUT AVE., CHINO, CA 91710 WEB SITE: www.desco.com
PHONE (909) 627-8178 FAX (909) 627-7449 FAX REQUEST (909) 627-7126
DESCO EAST: 90 HUDSON RD, CANTON, MA 02021-1407
PHONE (781) 821-8370 FAX (781) 575-0172

DRAWING NUMBER
09041

DATE:
7/99

